

FLOOR-EQUIPMENT-PARTS.COM

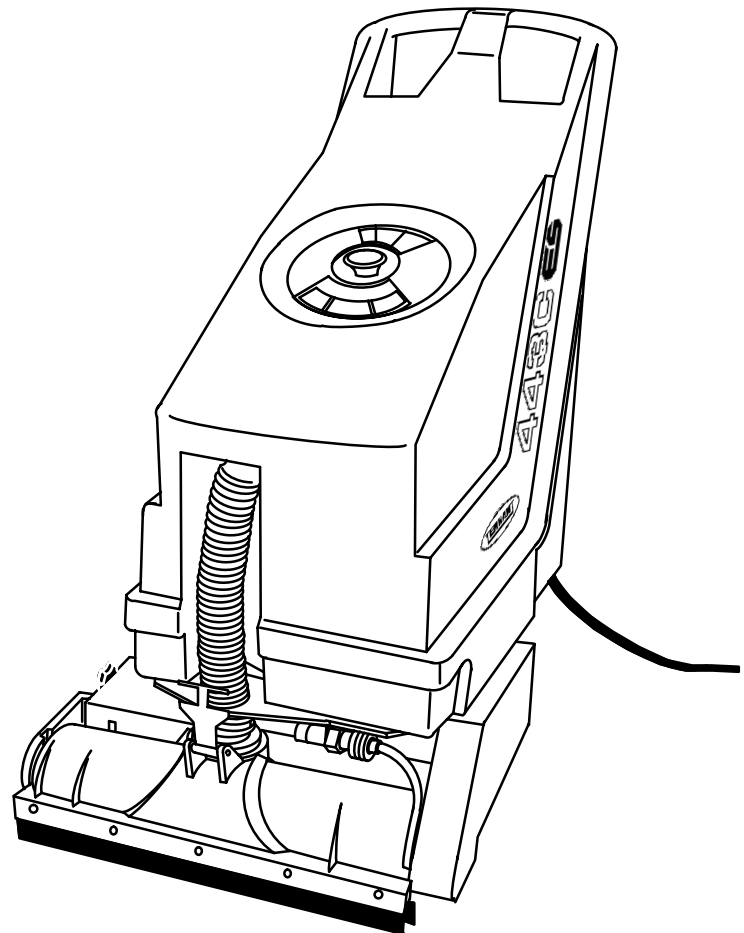

443C

Parts Manual



MM294
578-748
Rev. 05 (06-93)



This manual is furnished with each new TENNANT Model 443C.

This manual consists of the Standard Parts; Options; Breakdowns; and Cross Reference sections.

All right side and left side references to the machine are determined by facing the direction of forward travel. All hardware considered to be of a common nature or locally available has been omitted from the parts sections. Be aware that this machine may contain metric hardware. Make sure you use equivalent hardware when replacement becomes necessary.

This machine will provide excellent service. However, the best results will be obtained at minimum costs if:

- The machine is operated with reasonable care.
- The machine is maintained regularly – per the maintenance instructions provided.
- The machine is maintained with TENNANT supplied or equivalent parts.

Parts and supplies may be ordered by phone or mail from any TENNANT parts and service center, distributor, or from any of the TENNANT subsidiaries. Before ordering parts or supplies, be sure to have your machine model number and serial number handy. Fill out the data block below for future reference.

MACHINE DATA <i>Please fill out at time of installation.</i>
Machine Serial Number – _____
Sales Representative – _____
Customer Number – _____
Date of Installation – _____
Manual Number – MM294
Revision: 05
Published: 06–93

HOW TO USE THIS MANUAL

This section on *HOW TO USE THIS MANUAL* will tell you how to:

- Find important machine information for ordering correct repair parts.
- Find TENNANT part numbers.
- Order TENNANT parts and supplies.

IMPORTANT INFORMATION

When placing an order for parts, the machine model and machine serial number are important. Refer to the *MACHINE DATA* box which is filled out during the installation of your machine. The *MACHINE DATA* box is located on the inside of the front cover of this manual.

MACHINE DATA	
<i>Please fill out at time of installation.</i>	
Machine Serial Number -	_____
Sales Representative -	_____
Customer Number -	_____
Date of Installation -	_____
Manual Number -	MM294
Revision:	04
Published:	01-93

The model number of your machine is on the side of the machine.

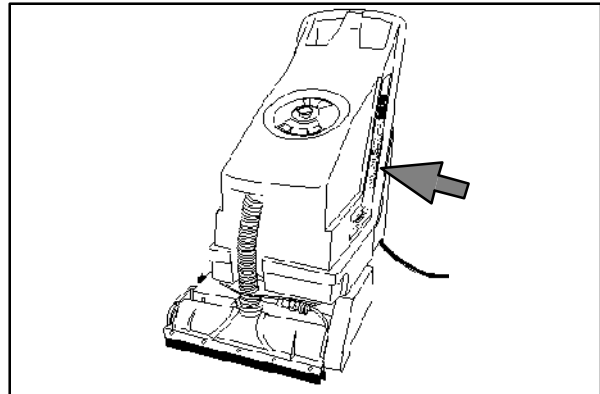

The serial number of your machine is printed on the machine data plate located as shown.

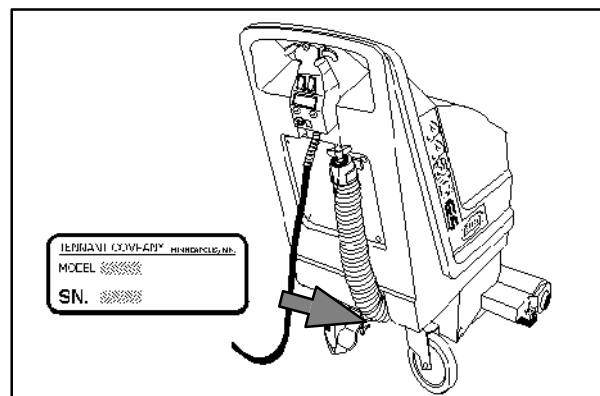

HOW TO USE THIS MANUAL

FINDING A TENNANT PART NUMBER

This manual contains the following sections:

- HOW TO USE THIS MANUAL
- STANDARD PARTS
- OPTIONS
- BREAKDOWNS
- CROSS REFERENCE

The STANDARD PARTS section lists repair parts for standard machines. They are grouped in this general order:

- General wear parts.
- Machine frame and related parts.
- Machine propelling system.
- Scrubbing components.
- Electrical parts.

The OPTION section lists repair parts of options.

The BREAKDOWN section lists available repair parts of major components.

All sections in this manual consist of parts illustrations and corresponding parts lists.

The parts illustrations are numbered with **Ref** numbers which refer to corresponding parts lists.

The parts lists include a number of columns of information:

- **Ref** – column refers to the reference number on the parts illustration.
- ∇ – indicates the part is an assembly.
- ▲ – indicates the part is included in the assembly listed just before it.
- **TENNANT Part No.** – column lists the TENNANT part number for the part.
- **Serial Number** – column indicates the set of machines the part number is applicable to. Serial numbers change when the machine design has been modified. The most current design of the machine is shown in the main illustration, older designs are boxed in a corner of the illustration.
- **Description** – column is a brief description of the part.
- **Qty.** – column lists the quantity of that part used in that area of the machine.

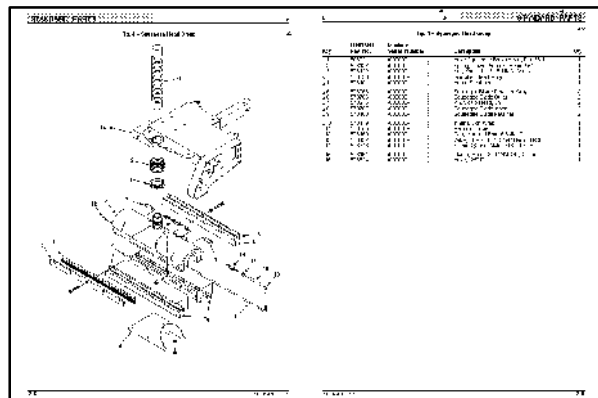

Key	TENNANT Part No.	Machine Serial Number	Description	Qty.
1	53302	000000	Hoze Squeegee Brush Head, 36, 38"	-
2	578122	000000	Spare, Lion Housse Head 2.5"	-
3	578122	000000	Nut, Pin, 1- 3/16 UNF, Special	-
4	578830	000000	Surfber Head Assy	-
4	57810	000000	Head, Scrubber	-
▲ 6	578263	000000	Squeegee Blade Retainer, Gray	2
▲ 6	578706	000000	Squeegee Blade Cutter	2
▲ 7	570210	000000	Pin, Scrub Bleed, SS	2
▲ 8	578707	000000	Squeegee Blade Inscr	2
▲ 9	578108	000000	Squeegee Blade Retainer	2
▲ 11	578114	000000	Inner Hous Wrap	-
11	578055	000000	Manifold, Tube	-
12	578150	000000	Cap, Manifold End, 5/8MM ID	-
13	578437	000000	Valve, Check, 1/4" X 1/4" Bore, 5 PSI	-
14	578116	000000	Filter, 1/2" Dia, 1/4" X 1/4" Bore	-
15	57816	000000	Clamp, Hose, 8-11MM CC, Clamp	-
16	578824	000000	Hose, 1/2" ID	-

NOTE: If a service kit is installed on your machine, be sure to keep the **INSTRUCTION BULLETIN** which came with the kit. It contains repair parts numbers needed for ordering future parts.

NOTE: Fasteners used in this machine may be metric or non-metric. Take care when replacing hardware to replace with same thread size.

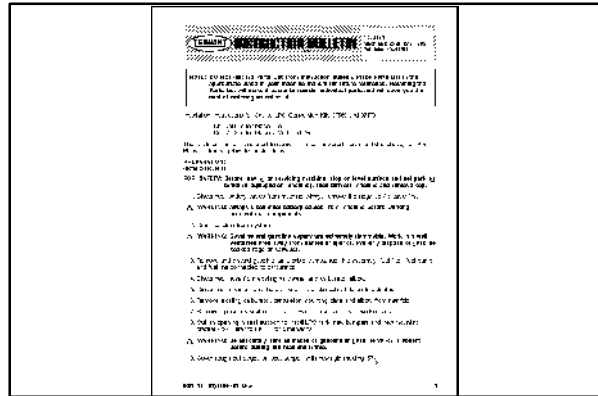

PLACING AN ORDER

Orders may be placed by phone, fax, or by mail. Phone orders may need written confirmation. Follow the steps below to insure prompt delivery:

1. Identify the model number of your machine.
2. Identify the serial number of your machine.
3. Find the part number of the part you need. Do not order by page number or reference number. If you are not able to find the part number, call your TENNANT representative for help or send the old part as a sample.
4. Determine the quantity of the part you need.
5. Provide the following company information:
 - Company name
 - Customer ID Number
 - Shipping address
 - Billing address
 - First and last name of person ordering parts
 - Telephone number
 - Purchase order number
6. Provide definitive shipping instructions.

HOW TO USE THIS MANUAL

Any claim for loss or damage to a shipment in transit should be filed promptly with the transportation company making the delivery. Shipments will be complete unless the packing list or order acknowledgement indicates items back ordered.

If parts received are suspected to be incorrect or defective, please contact the TENNANT representative from whom you ordered the part. They will give authorization for return and/or handle replacement shipments when required.

SECTION 2**CONTENTS**

	Page
Fig. 1 – Motor Frame Group	2-2
Fig. 2 – Tank Group	2-4
Fig. 3 – Transport Group	2-6
Fig. 4 – Squeegee Head Group	2-8
Fig. 5 – Electrical Panel	2-10
Fig. 6 – Electrical Schematic	2-12

Fig. 1 – Motor Frame Group

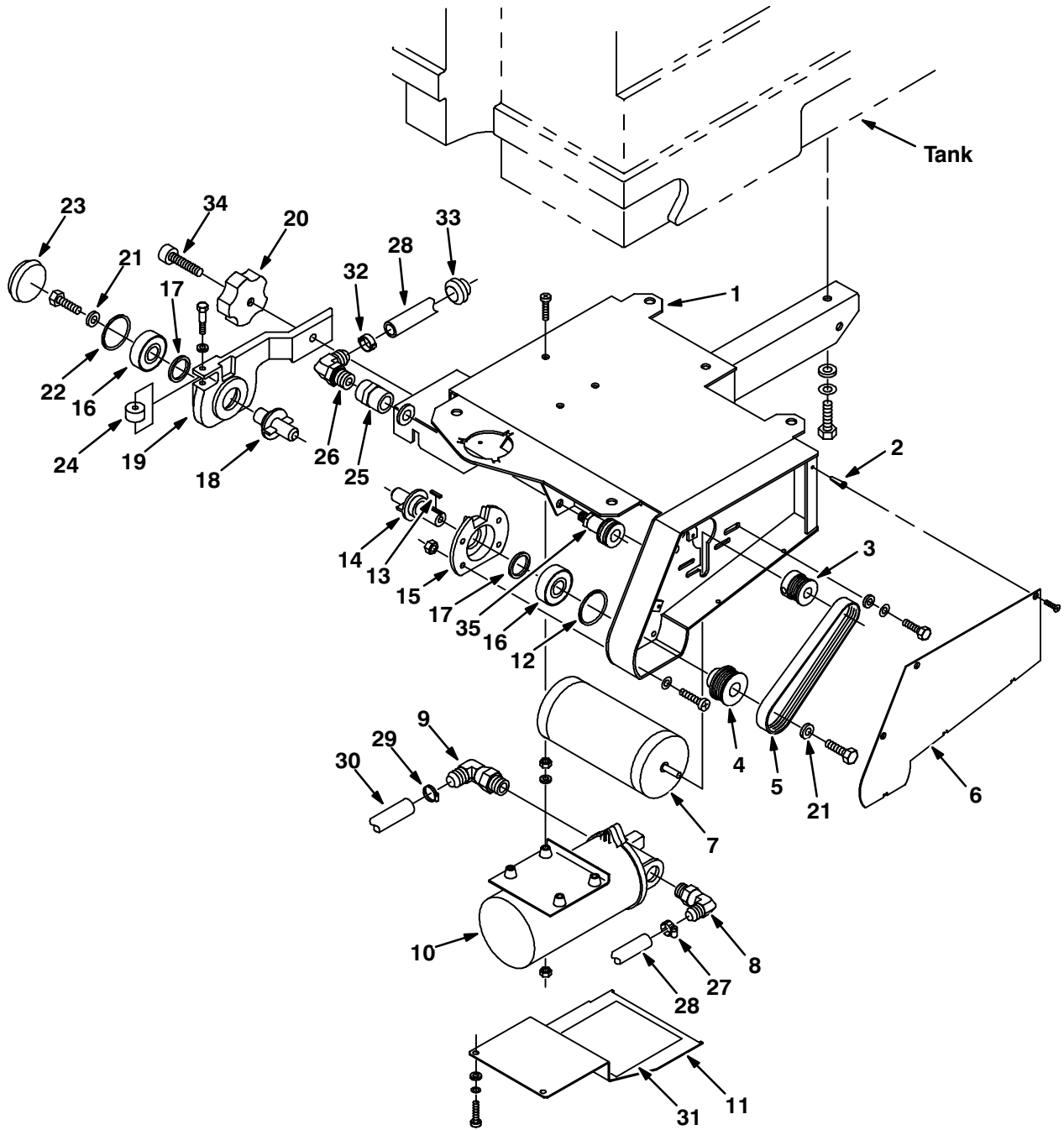

Fig. 1 – Motor Frame Group

Key	TENNANT Part No.	Machine Serial Number	Description	Qty.
1	578170	(000000–)	Frame, Motor	1
2	578329	(000000–)	Screw Anchor #6	3
3	578414	(000000–)	Pulley, Motor	1
4	578413	(000000–)	Pulley, Brush	1
5	578118	(000000–)	Belt, Poly–V, Length 381MM	1
6	578182	(000000–)	Cover, Belt	1
7	578028	(000000–)	Motor, Brush (See Breakdowns)	1
8	578040	(000000–)	Fitting, Elbow, 3/8NPT X .25 Hose	1
9	578039	(000000–)	Fitting, Elbow, .50" Hose, .38"NPT	1
10	578331	(000000–)	Pump, 115 VAC (See Breakdowns)	1
11	578181	(000000–)	Cover, UL	1
12	578319	(000000–)	O-Ring, 1.56"ID, 1.75"OD, Buna	1
13	578416	(000000–)	Key, Square, .125" X .125" X .50"	1
14	578597	(000000–)	Plug, Brush, Driver	1
15	578163	(000000–)	Mount, Bearing	1
▽	578801	(000000–)	Removable Brush Arm Assy	1
▲ 16	578415	(000000–)	Bearing, Ball	2
▲ 17	578138	(000000–)	Seal, Oil, Bearing, .94"ID, 1.31"OD	2
▲ 18	578111	(000000–)	Plug, Brush, Idler	1
▲ 19	578577	(000000–)	Arm, Brush, Removable	1
▲ 20	578156	(000000–)	Knob, Removable Arm	1
▲ 21	578261	(000000–)	Washer, Belleville, .31", .83", ZP	2
▲ 22	578102	(000000–)	Ring, Retaining, Internal	1
▲ 23	578251	(000000–)	Cap, Bearing, Brush	1
▲ 24	578579	(000000–)	Spacer	1
25	578274	(000000–)	Fitting, Coupling, 0.25"NPT Brass	1
26	578273	(000000–)	Fitting, Elbow, 1.25 Hose, 0.25"NPT	1
27	578434	(000000–)	Clamp, Hose-Extravac™	1
28	578823	(000000–)	Hose, .25"ID	1
29	575500	(000000–)	Clamp, Hose, Ideal 62606, .31 – .89	1
30	578822	(000000–)	Hose, .50"ID	1
31	578747	(000000–)	Decal, Wiring	1
32	578161	(000000–)	Clamp, Hose, 8–11MM OD, Crimp	1
33	578304	(000000–)	Grommet, 13.2MM ID	1
34	578249	(000000–)	Screw, Socket Hd, .38"–16 X 1.50", ZP	1
35	575520	(000000–)	Quick Connect, F 3/8" X 1/4"MPT	1

Fig. 2 – Tank Group

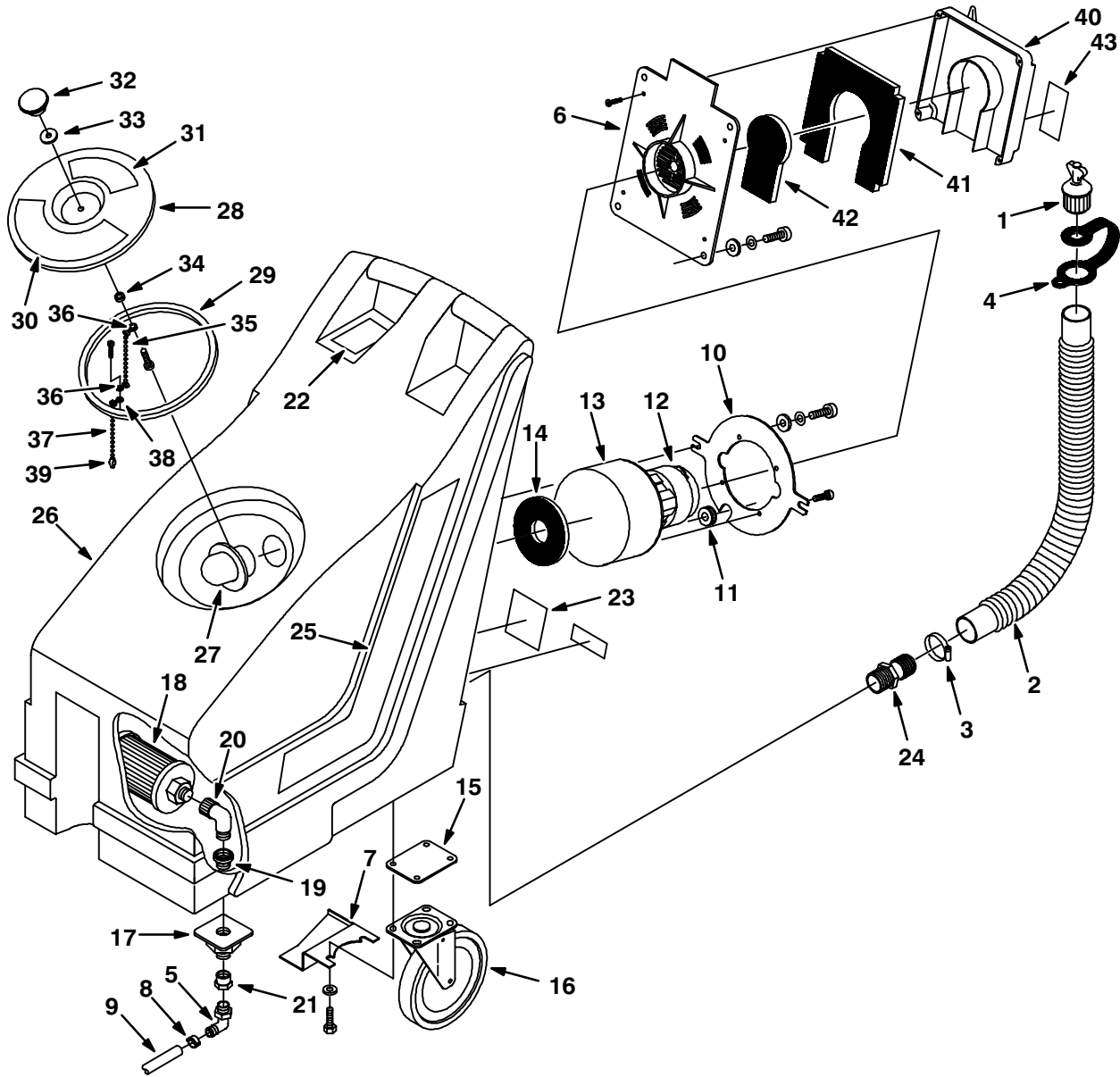

Fig. 2 – Tank Group

Key	TENNANT Part No.	Machine Serial Number	Description	Qty.
▽	578802	(000000–)	Drain Hose Assy.	1
▲ 1	621324	(000000–)	Plug, Expansion 1–5 Dia. Nylon	1
▲ 2	578031	(000000–)	Hose, Drain	1
▲ 3	578428	(000000–)	Clamp, Hose, Ideal 6428, 1.32–2.2	1
▲ 4	578441	(000000–)	Strap, Drain Hose	1
5	578037	(000000–)	Fitting, Elbow, 0.50" Hose, 0.75"	1
6	578018	(000000–)	Cover, Vac Motor	1
7	578727	(000000–)	Cover, Sound	1
8	578162	(000000–)	Clamp, Crimp, 17–20MM OD Hose, SS	1
9	578822	(000000–)	Hose, .50" ID	1
10	578016	(000000–)	Bracket, Vac Motor	1
11	578009	(000000–)	Grommet, .50" ID, 0.81"GD, 0.12"GW	1
12	578417	(000000–)	Transition, Motor	1
13	578328	(000000–)	Motor, Vac (See Breakdowns)	1
14	578424	(000000–)	Gasket, Foam, 102 OD, 38ID, 9.5	1
15	578230	(000000–)	Shim, 95.0MM 70.0MM, 20Ga., ZP	2
16	578012	(000000–)	Caster, 6"Dia.	2
17	621139	(000000–)	Fitting Bulkhead 1 NPT	1
18	578445	(000000–)	Filter, Screen, 3.5" X 6", 100 Mesh	1
19	578446	(000000–)	Fitting, Riser Extension, 1"	1
20	578034	(000000–)	Fitting, Elbow, 1"NPT, Street	1
21	578036	(000000–)	Fitting, Bushing, 1"MPT X 3/4"FPT	1
▽	578831	(000000–)	Solution Tank Assy.	1
▲ 22	578229	(000000–)	Decal, Read Manual	1
▲ 23	578725	(000000–)	Decal, Brush Pressure Adjustment	1
▲ 24	621277	(000000–)	Fitting, Straight, 1.5 Hose X 1.25NPT	1
▲ 25	578743	(000000–)	Decal, Left and Right Side	1
▲ 26	578710	(000000–)	Tank, Recycle	1
▲ 27	578020	(000000–)	Screen, Vacuum Fan	1
▽	578800	(000000–)	Fill Cover Assy.	1
▲ 28	578026	(000000–)	Cover, Fill	1
▲ 29	578816	(000000–)	Gasket, .50" X .50" X 650mm	1
▲ 30	578267	(000000–)	Decal, Flammable Materials	1
▲ 31	578222	(000000–)	Decal, Filling Instructions	1
▲ 32	578301	(000000–)	Knob, Fill Cover, 10–32 F	1
▲ 33	575601	(000000–)	Washer, Rubber	1
▲ 34	575010	(000000–)	Washer, Sealing	1
▲▽	578805	(000000–)	Ball Chain Assembly, Cover	1
▲▲ 35	578312	(000000–)	Chain Ball #10	1
▲▲ 36	575536	(000000–)	End Coupling, Chain	2
▲▽	578806	(000000–)	Ball Chain Assembly, Level	1
▲▲ 37	578313	(000000–)	Chain Ball #10	1
▲▲ 38	575536	(000000–)	End Coupling, Chain	1
▲▲ 39	575538	(000000–)	Spacing Link	1
▽	578733	(000000–)	Cover Sound Assembly	1
▲ 40	578713	(000000–)	Cover	1
▲ 41	578711	(000000–)	Foam	1
▲ 42	578712	(000000–)	Foam	1
▲ 43	578268	(000000–)	Decal, Hazardous Voltage	1

Fig. 3 – Transport Group

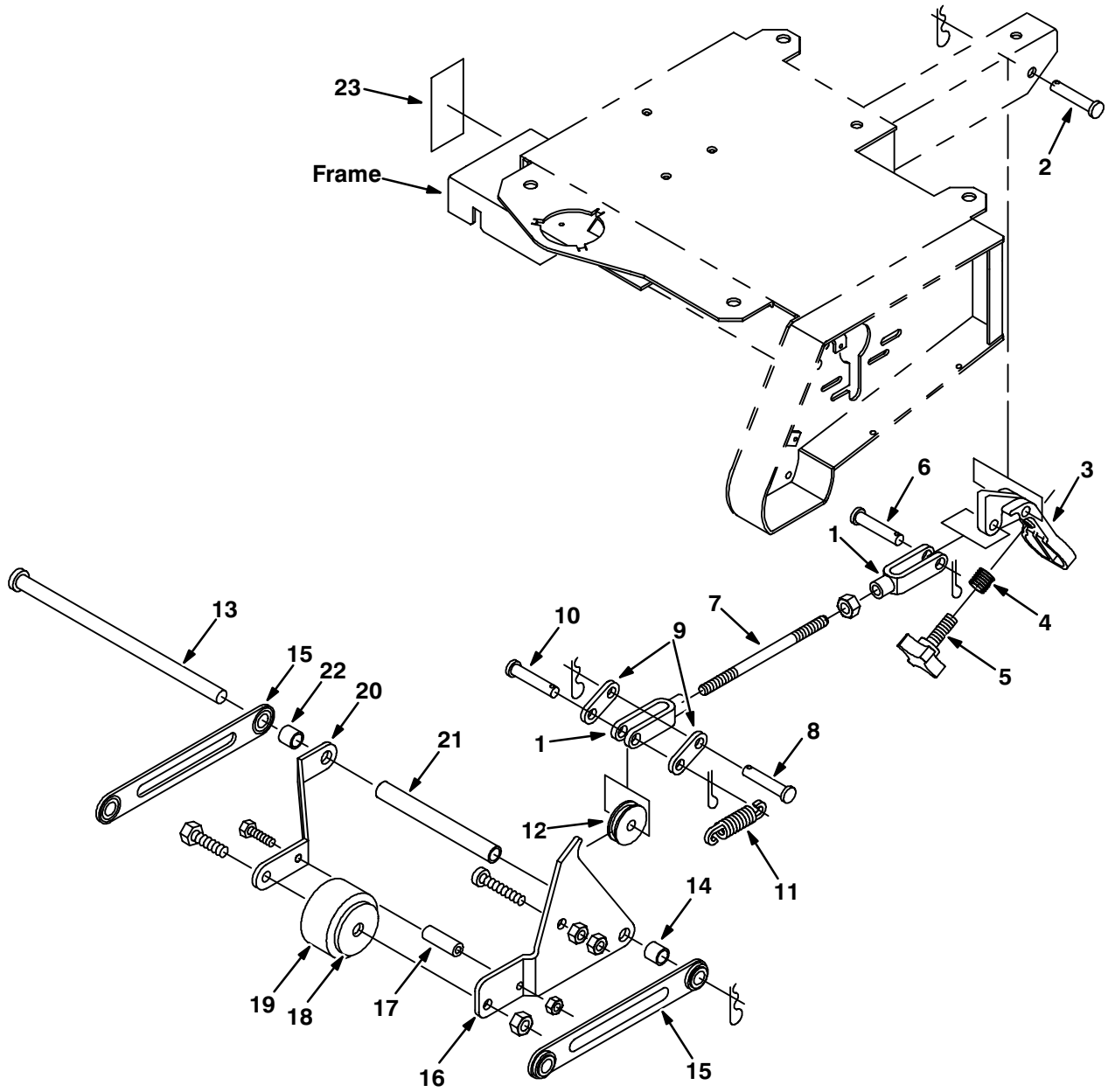

Fig. 3 – Transport Group

Key	TENNANT Part No.	Machine Serial Number	Description	Qty.
1	578085	(000000–)	Yoke, Adjustable, 3/8–24 UNF,–2B–RH, ZP	2
2	601103	(000000–)	Pin, Clevis, .38 X 1.75" Lg.	1
3	578135	(000000–)	Pedal, Transport	1
4	578140	(000000–)	Spring, Compression, 1.00", 0.66", .049	1
5	578139	(000000–)	Knob, Foot Pedal, Male	1
6	578158	(000000–)	Pin, Clevis, .38"Dia. X 0.90"EFF, ZP	1
7	578132	(000000–)	Rod, Transport, 153MM, 3/8–24	1
8	578202	(000000–)	Pin, Clevis, .38"Dia. X 1.50" Lg.	1
9	578129	(000000–)	Transport Wheel Arm	2
10	578231	(000000–)	Pin, Clevis, 38"Dia. X 2.00"Lg	1
11	578425	(000000–)	Spring, Extension, .63", 3.00, .63	1
12	578130	(000000–)	Cam, Transport Wheel	1
13	578220	(000000–)	Transport Pin	1
14	578217	(000000–)	Spacer, 13.8MM ID X 21.3 OD X 14.7MM Lg	1
15	578104	(000000–)	Arm, Brush Wrap	2
16	578136	(000000–)	Left Arm, Transport	1
17	578137	(000000–)	Spacer, 6.4 ID X 12.7 OD X 39.7 Lg., ZP	1
18	578116	(000000–)	Guard, Thread Wheel	2
19	578115	(000000–)	Wheel, Transport	1
20	578128	(000000–)	Right Arm, Transport	1
21	578219	(000000–)	Spacer, 13.8 ID, 21.3OD, 140MM Lg	1
22	578218	(000000–)	Spacer, 13.8MM ID, 21.3MM OD X 8.6MM Lg	1
23	578269	(000000–)	Decal, Moving Parts	1

Fig. 4 – Squeegee Head Group

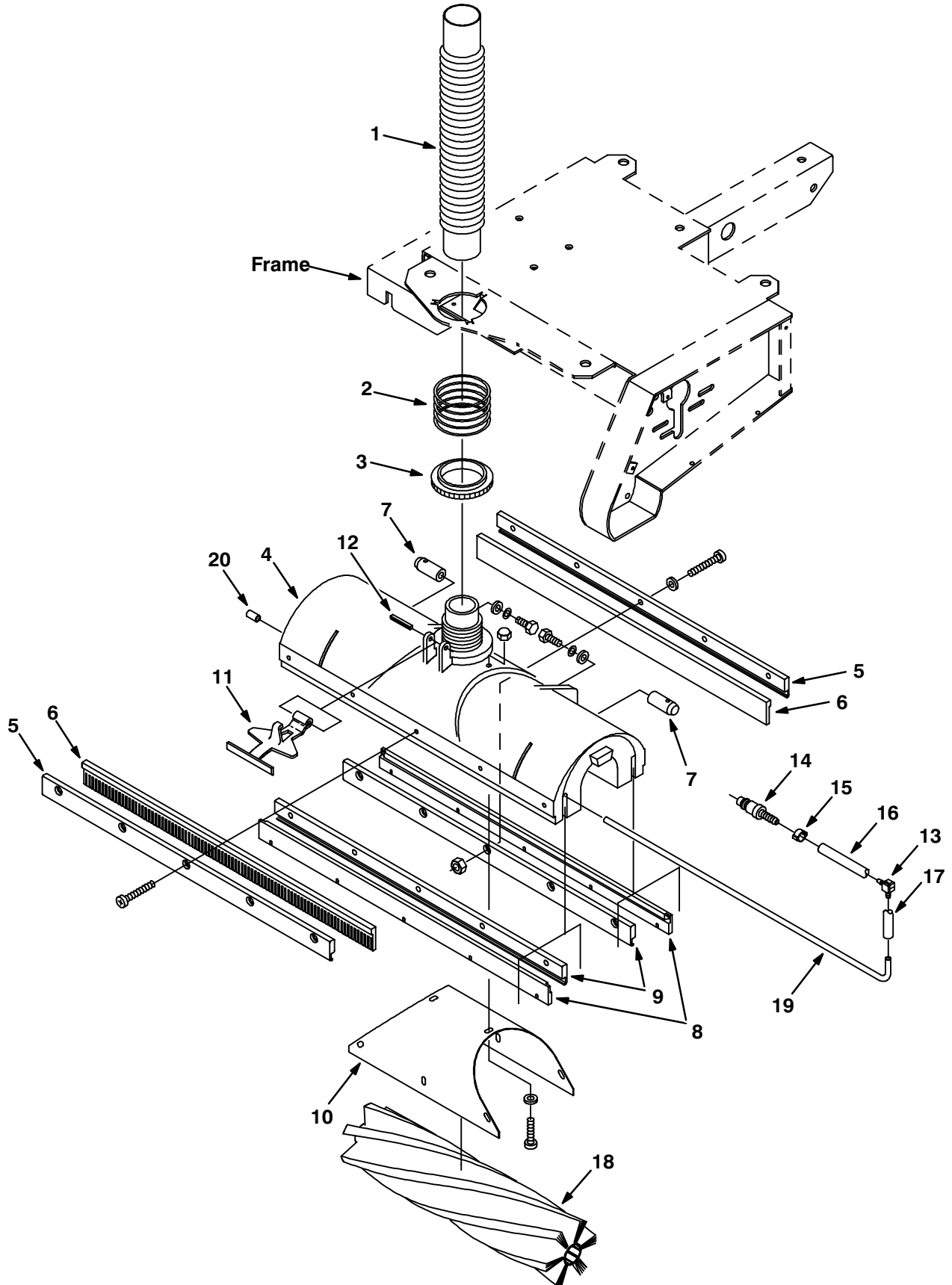

Fig. 4 – Squeegee Head Group

Key	TENNANT Part No.	Machine Serial Number	Description	Qty.
1	578021	(000000–)	Hose Squeegee Brush Head, Dia. 38.1	1
2	578127	(000000–)	Spring, Down Pressure Head 2.5"	1
3	578122	(000000–)	Nut, Knurl, 1–13/16 UNC, Special	1
▽	578830	(000000–)	Scrubber Head Assy	1
▲	4 578101	(000000–)	Head, Scrubber	1
▲	5 578591	(000000–)	Squeegee Blade Retainer, Gray	2
▲	6 578706	(000000–)	Squeegee Blade Outer	2
▲	7 578216	(000000–)	Pin, Scrub Head, SS	2
▲	8 578707	(000000–)	Squeegee Blade Inner	2
▲	9 578592	(000000–)	Squeegee Blade Retainer	2
▲	10 578119	(000000–)	Inner Brush Wrap	1
▲	11 579100	(xxxxxx–)	Latch, Double Scrub	1
▲	12 579059	(xxxxxx–)	Pin, Spring Lock	1
13	578437	(000000–)	Valve, Check 1/4" X 1/4" Barb, 3 PSI	1
14	578318	(000000–)	Fitting, QConn, Male, 3/8", 1/4" H	1
15	578161	(000000–)	Clamp, Hose, 8–11MM OD, Crimp	1
16	578569	(000000–)	Hose, .25" ID X .115M Lg	1
17	578571	(000000–)	Hose, .25" ID X .030M Lg	1
18	578112	(000000–)	Brush, Cylindrical	1
19	578055	(000000–)	Manifold, Tube	1
20	578150	(000000–)	Cap, Manifold End, 5.8MM ID	1

Fig. 5 – Electrical Panel

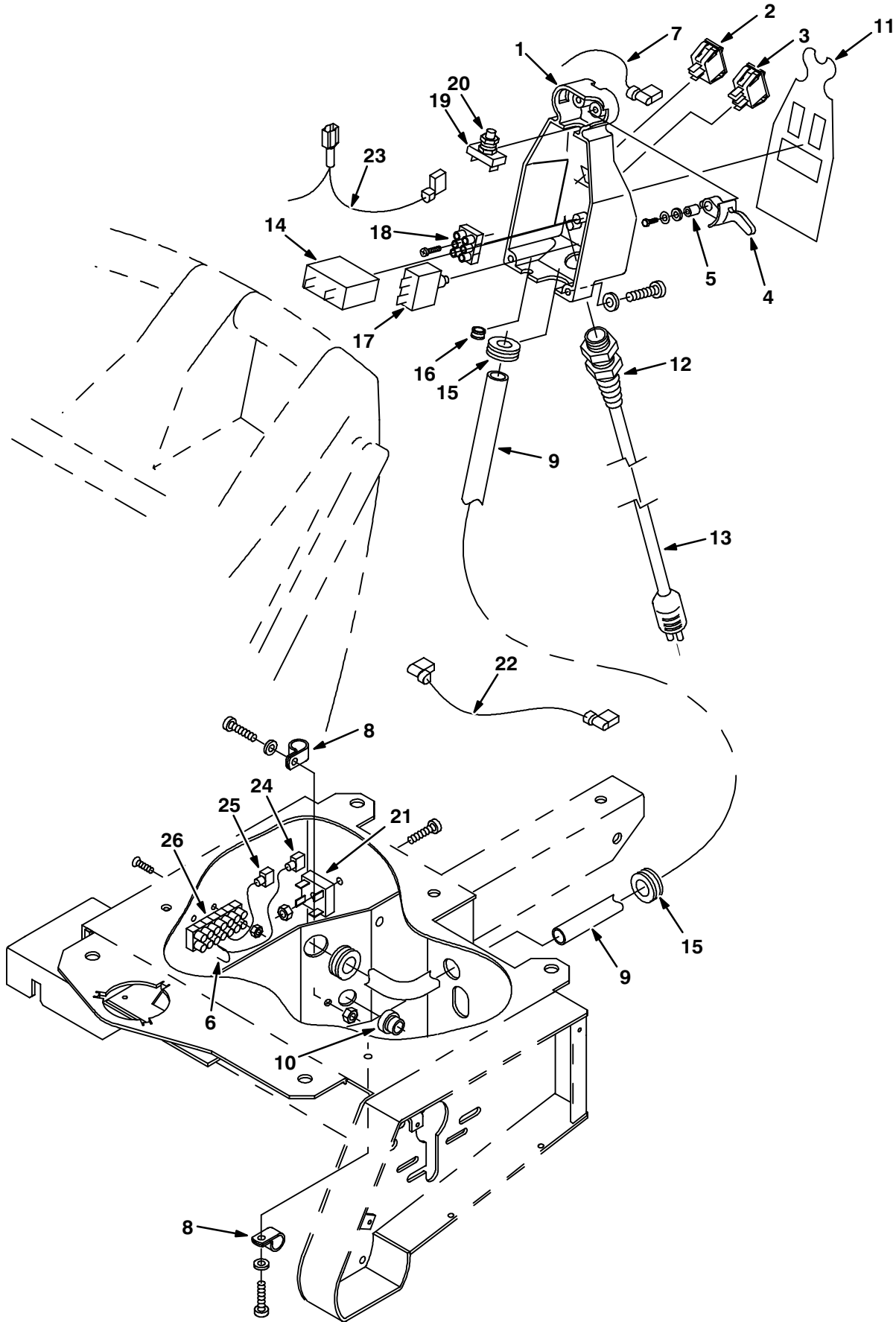
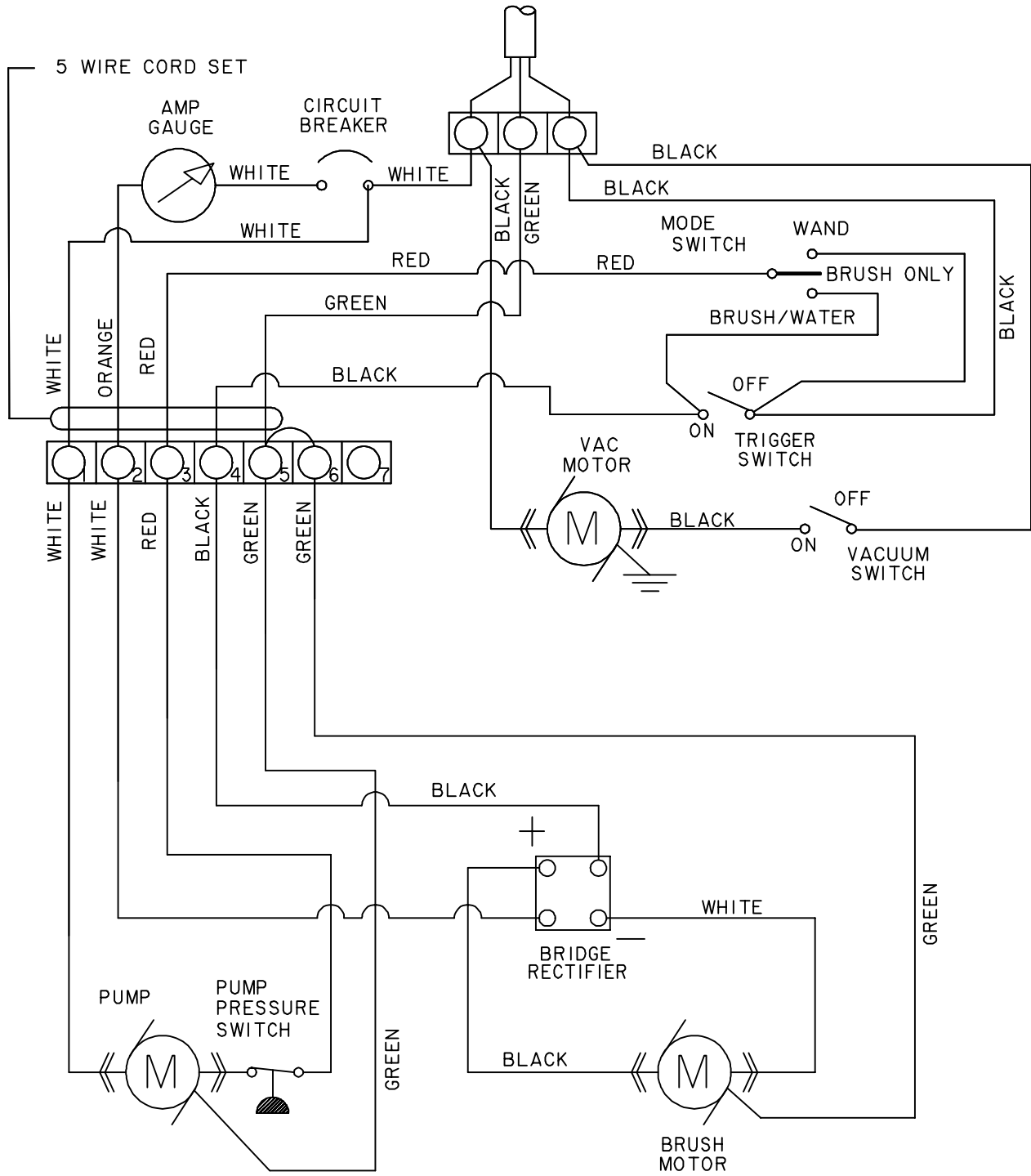

Fig. 5 – Electrical Panel

Key	TENNANT Part No.	Machine Serial Number	Description	Qty.
1	578001	(000000–)	Cover, Console	1
2	578005	(000000–)	Switch, Rocker SPST	1
3	578272	(000000–)	Switch, Rocker, SPDT	1
4	578002	(000000–)	Arm, Trigger	2
5	578082	(000000–)	Spacer, Trigger	2
6	578259	(000000–)	Wire, Jumper, Green	1
7	578029	(000000–)	Wire Assy, 16 Ga, 120MM FQC/TIN	1
8	578256	(000000–)	Clamp, Cable, .44"ID	2
9	578058	(000000–)	Wire Harness	1
10	578324	(000000–)	Strain Relief, Motor Leads	1
11	578779	(000000–)	Decal, "Console"	1
12	578079	(000000–)	Strain Relief Cord, Pigtail	1
13	578023	(000000–)	Cord Set, 14/3SJT, Yellow, 40' Lg	1
14	578054	(000000–)	Gauge, Brush Pressure	1
15	578009	(000000–)	Grommet, .50" ID, 0.81GD, .12"GW	3
16	578080	(000000–)	Grommet, .1" ID, .31"GD, .12"GW	1
17	578004	(000000–)	Circuit Breaker, 3AMP	1
18	578007	(000000–)	Terminal Block 3 Position	1
19	578423	(000000–)	Switch, Pushbutton, SPNO	1
20	578430	(000000–)	Spring, Disc.	1
21	578083	(000000–)	Rectifier, Full Wave	1
22	578075	(000000–)	Wire Assy, 16 Ga, 90MM FQC	1
23	578260	(000000–)	Wire Assy, 16 Ga	1
24	578252	(000000–)	Wire, Jumper, White	1
25	578255	(000000–)	Wire, Jumper, Black	1
26	578013	(000000–)	Terminal Block, 7 Pos.	1

Fig. 6 – Electrical Schematic



06611

SECTION 3

CONTENTS

	Page
Fig. 1 – Hard Floor Wand	3-2
Fig. 2 – Hose Assembly	3-4
Fig. 3 – Grit Brush	3-5

Fig. 1 – Hard Floor Wand

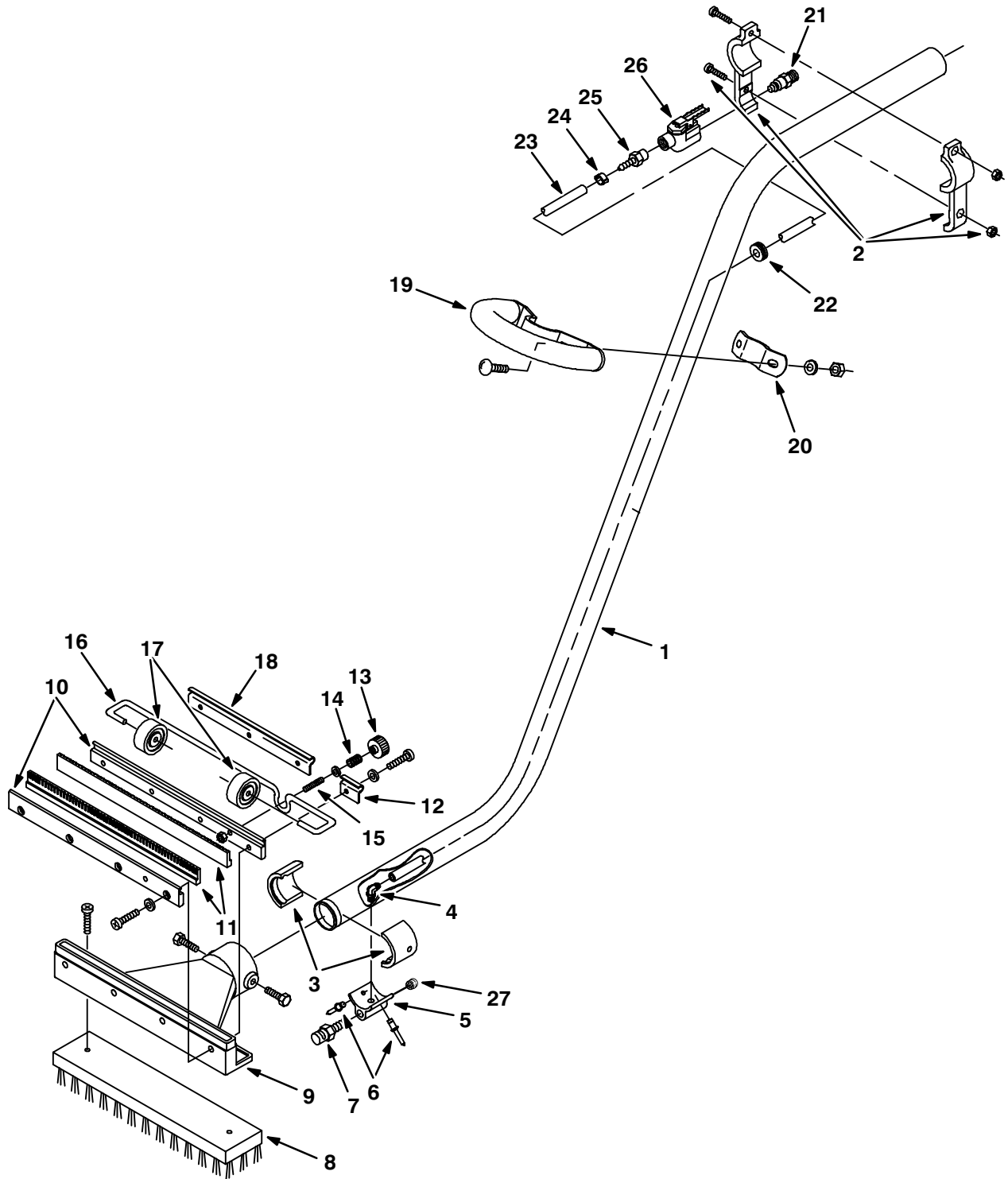
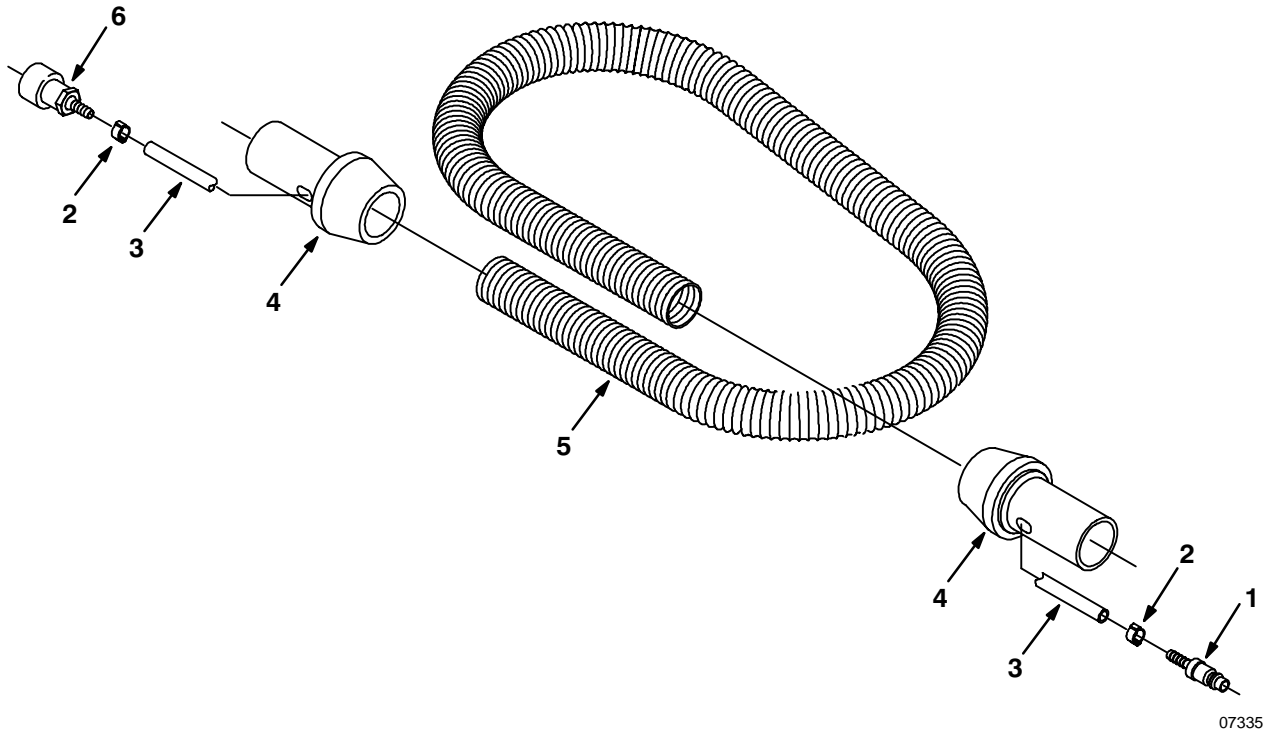

Fig. 1 – Hard Floor Wand

Key	TENNANT Part No.	Machine Serial Number	Description	Qty.
▽ 1	578060	(000000–)	Wand Assy, Double Bend, Dia 38.1MM	1
▲ 2	578077	(000000–)	Bracket, Valve Mounting, Wand	1
▲ 3	578061	(000000–)	Adapter, Head/Wand	2
▲ 4	578214	(000000–)	Fitting, Elbow, 0.25”Hose, 0.12”NPT	1
▲ 5	579112	(000000–)	Adapter, Spray Nozzle	1
▲ 6	579198	(000000–)	Rivet, Pop, S–2500 Driveblock	2
▲ 7	578066	(000000–)	Spray Nozzle, .125” NPT, 75 Deg.	1
▲ 8	578073	(000000–)	Brush, Wand Attachment	1
8	65582	(000000–)	Brush–Scrub, Retang, Block–AB	1
▲ 9	578063	(000000–)	Head, Wand	1
▲ 10	578078	(000000–)	Retainer, Squeegee Wand	2
▲ 11	578074	(000000–)	Blade, Squeegee Wand	2
▲ 12	578124	(000000–)	Bracket, Axle, 1–Hole	1
▲ 13	578439	(000000–)	Nut, Thumb, MO6 X Dia 30MM	1
▲ 14	578228	(000000–)	Spring, Compression, .63”, .42”, .04	1
▲ 15	578143	(000000–)	M6, 40mm Lg., Adjust. Stud	1
▲ 16	578126	(000000–)	Axle, Wand	1
▲ 17	578125	(000000–)	Wheel, Guide, Wand	2
▲ 18	578123	(000000–)	Bracket, Axle, 3–Hole	1
▲ 19	578155	(000000–)	Handle, Wand	1
▲ 20	578154	(000000–)	Bracket, Handle, Wand	1
▲ 21	578091	(000000–)	Male Quick–Conn., 1/4”NPT	1
▲ 22	578164	(000000–)	Grommet, .38”ID. .63”OD, .06”OW	1
▲ 23	578821	(000000–)	Hose, Solution, Wand	1
▲ 24	578161	(000000–)	Clamp, Hose, 8–11MM OD, Crimp	2
▲ 25	578094	(000000–)	1/4 Hosebarb, 3/8NPT Male Pipe	1
▲ 26	578064	(000000–)	Valve, Water Control, Wand	1
▲ 27	579148	(000000–)	Fitting, Plug	1

Fig. 2 – Hose Assembly



07335

Key	TENNANT Part No.	Machine Serial Number	Description	Qty.
1	578318	(000000–)	Fitting, Quick conn.	1
2	578160	(000000–)	Clamp, hose	2
3	578820	(000000–)	Hose	1
4	578072	(000000–)	Cuff, swivel	2
5	578276	(000000–)	Hose, vacuum	1
6	578071	(000000–)	Connector, quick F.	1

Fig. 3 – Grit Brush

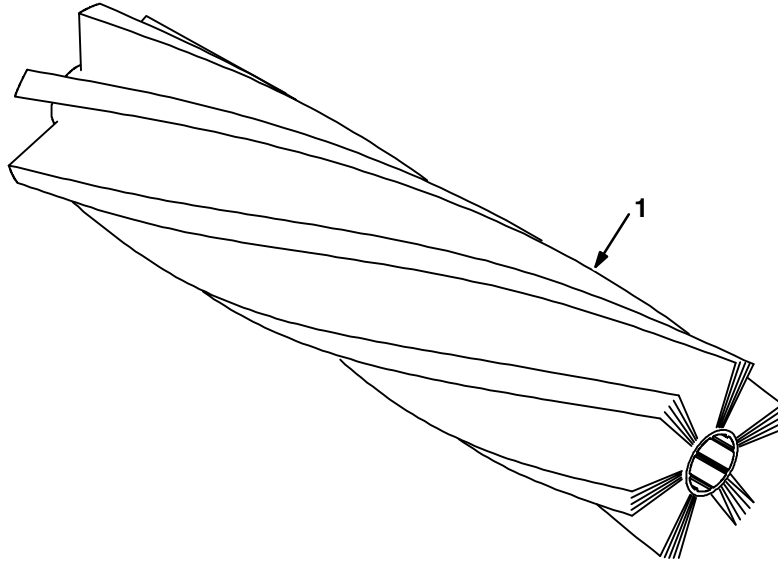

08313

Key	TENNANT Part No.	Machine Serial Number	Description	Qty.
1	578322	(000000–)	Brush, Nylo-Grit, 17", Cyl.	1

SECTION 4**CONTENTS**

	Page
Fig. 1 – Pump Motor	4-2
Fig. 2 – Vacuum Fan Assembly	4-3
Fig. 3 – Brush Motor	4-4

Fig. 1 – Pump Motor

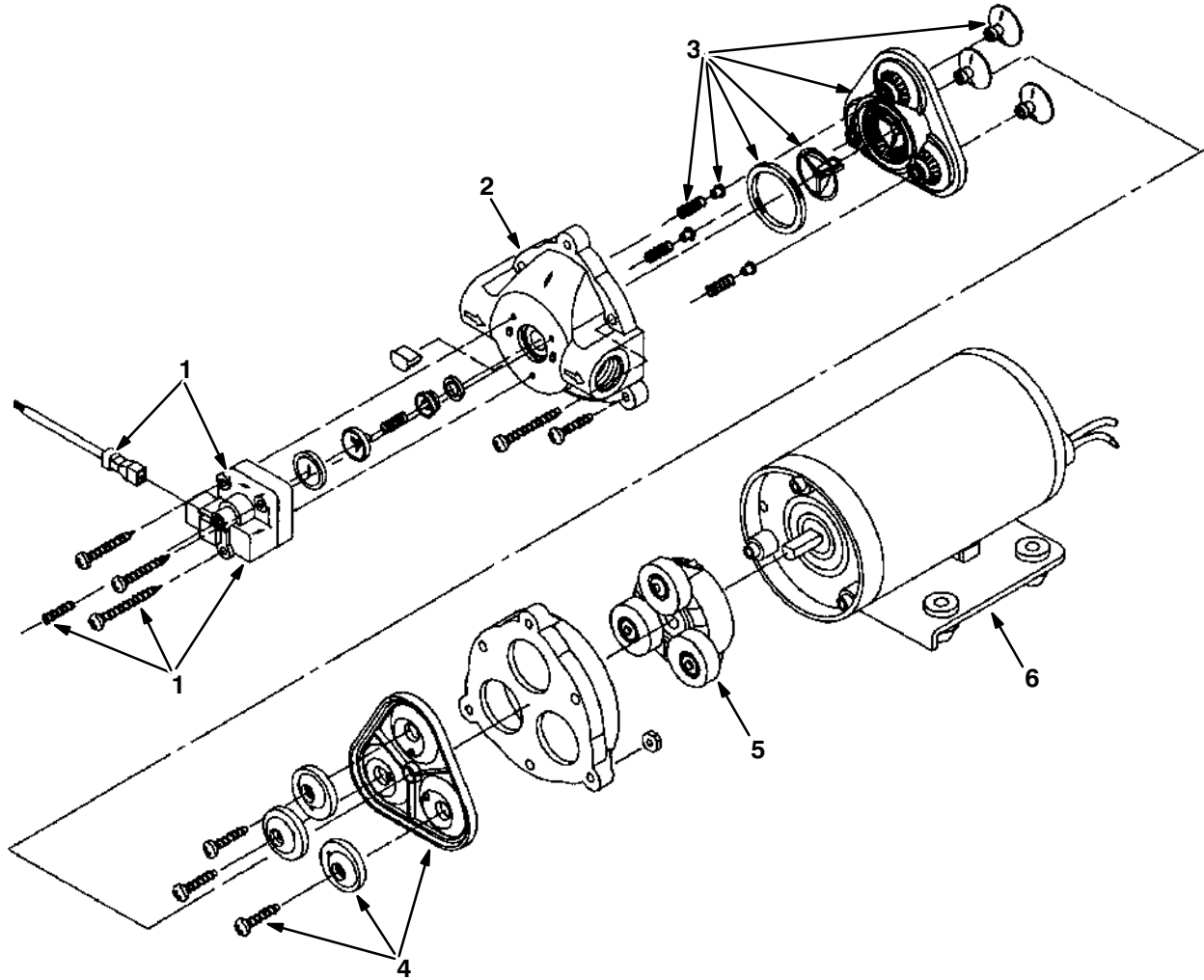

07177

Key	TENNANT Part No.	Machine Serial Number	Description	Qty.
∇	578331	(000000–)	Pump Motor Assy	1
▲∇	578807	(000000–)	Pump Head Assy	1
▲▲ 1	578812	(000000–)	Switch, Pressure	1
▲▲ 2	578813	(000000–)	Upper Housing	1
▲▲ 3	578811	(000000–)	Valves (Buna-N) 60 PSI Bypass	1
▲▲ 4	578810	(000000–)	Diaphragm (Geolast)	1
▲▲ 5	578809	(000000–)	Drive Assy – 2.0 CAM	1
▲▲ 6	578808	(000000–)	115 VAC Motor W/Rect.	1
▲▲	578814	(000000–)	Rectifier	1

Fig. 2 – Vacuum Fan Assembly

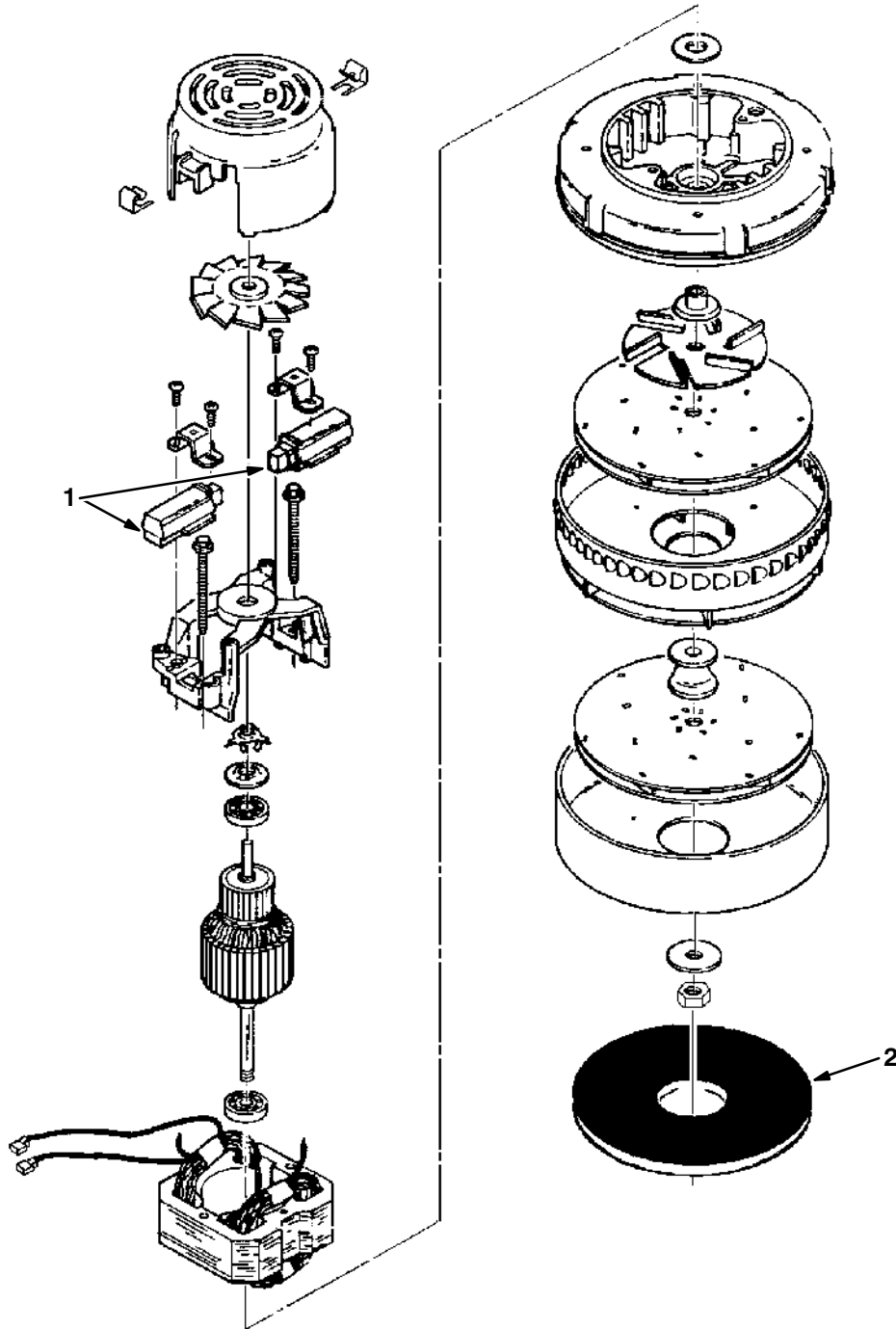

Key	TENNANT Part No.	Machine Serial Number	Description	Qty.
▽	578328	(000000–)	Vacuum Fan Assy	1
▲ 1	578429	(000000–)	Brush, Vac Fan Motor (Set of 2)	1
▲ 2	578424	(000000–)	Gasket, Foam, 102OD, 38ID, 9.5	1

07178

Fig. 3 – Brush Motor

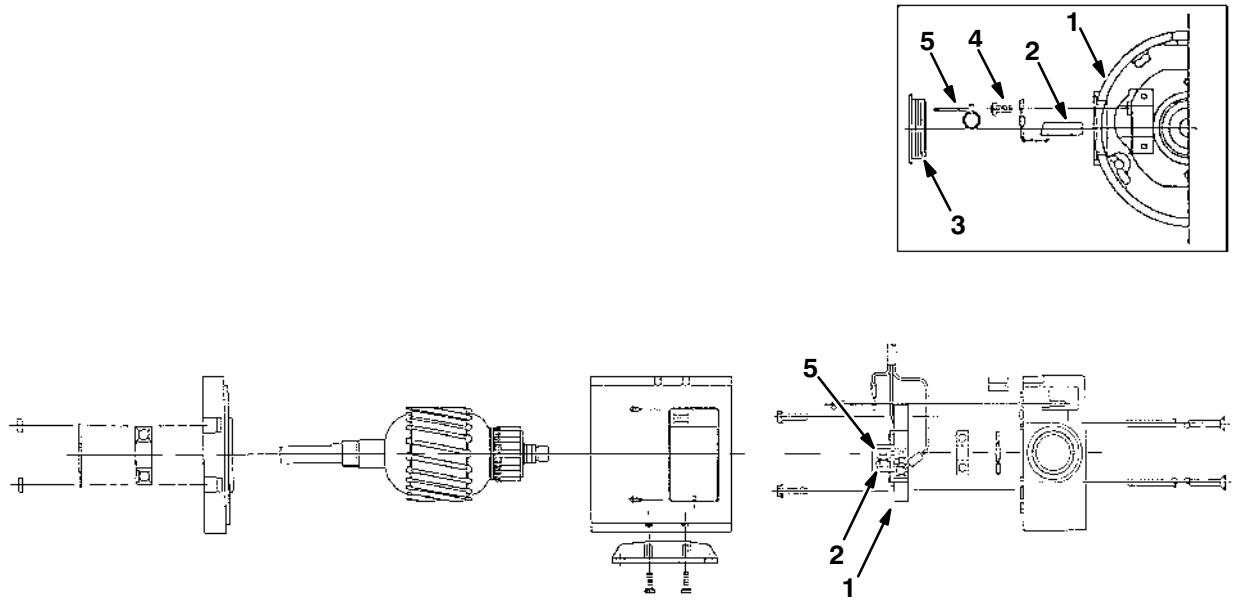

08906

Key	TENNANT Part No.	Machine Serial Number	Description	Qty.
▽	578028	(000000–)	Brush Motor Assy.	1
▲ 1	578885	(000000–)	Brush Insulator	1
▲ 2	578886	(000000–)	Brush Assembly	1
▲ 3	578887	(000000–)	Cap	2
▲ 4	578888	(000000–)	Screw	1
▲ 5	578889	(000000–)	Spring	1

SECTION 5

CONTENTS

	Page
PART NUMBER TO PAGE NUMBER CROSS REFERENCE LIST	5-2

CROSS REFERENCE

PART NUMBER TO PAGE NUMBER CROSS REFERENCE LIST

Part Number	Page Number	Part Number	Page Number
575010	2-5	578118	2-3
575052	2-11	578119	2-9
575500	2-3	578122	2-9
575520	2-3	578123	3-3
575536	2-5	578124	3-3
575538	2-5	578125	3-3
575601	2-5	578126	3-3
578001	2-11	578127	2-9
578002	2-11	578128	2-7
578004	2-11	578129	2-7
578005	2-11	578130	2-7
578007	2-11	578132	2-7
578009	2-5, 2-11	578135	2-7
578012	2-5	578136	2-7
578013	2-11	578137	2-7
578016	2-5	578138	2-3
578018	2-5	578139	2-7
578020	2-5	578140	2-7
578021	2-9	578143	3-3
578023	2-11	578150	2-9
578026	2-5	578154	3-3
578028	2-3, 4-4	578155	3-3
578029	2-11	578156	2-3
578031	2-5	578158	2-7
578034	2-5	578160	3-4
578036	2-5	578161	2-3, 2-9, 3-3
578037	2-5	578162	2-5
578039	2-3	578163	2-3
578040	2-3	578164	3-3
578054	2-11	578170	2-3
578055	2-9	578181	2-3
578058	2-11	578182	2-3
578060	3-3	578202	2-7
578061	3-3	578214	3-3
578063	3-3	578216	2-9
578064	3-3	578217	2-7
578066	3-3	578218	2-7
578071	3-4	578219	2-7
578072	3-4	578220	2-7
578073	3-3	578222	2-5
578074	3-3	578228	3-3
578075	2-11	578229	2-5
578077	3-3	578230	2-5
578078	3-3	578231	2-7
578079	2-11	578249	2-3
578080	2-11	578251	2-3
578082	2-11	578252	2-11
578083	2-11	578255	2-11
578085	2-7	578256	2-11
578091	3-3	578259	2-11
578094	3-3	578260	2-11
578101	2-9	578261	2-3
578102	2-3	578267	2-5
578104	2-7	578268	2-5
578111	2-3	578269	2-7
578112	2-9	578272	2-11
578115	2-7	578273	2-3
578116	2-7	578274	2-3

CROSS REFERENCE

Part Number	Page Number	Part Number	Page Number
578276	3-4	578814	4-2
578301	2-5	578816	2-5
578304	2-3	578820	3-4
578312	2-5	578821	3-3
578313	2-5	578822	2-3, 2-5
578318	2-9, 3-4	578823	2-3
578319	2-3	578830	2-9
578322	3-5	578831	2-5
578324	2-11	578885	4-4
578328	2-5, 4-3	578886	4-4
578329	2-3	578887	4-4
578331	2-3, 4-2	578888	4-4
578413	2-3	578889	4-4
578414	2-3	579059	2-9
578415	2-3	579100	2-9
578416	2-3	579112	3-3
578417	2-5	579148	3-3
578423	2-11	579198	3-3
578424	2-5, 4-3	601103	2-7
578425	2-7	621139	2-5
578428	2-5	621277	2-5
578429	4-3	621324	2-5
578430	2-11	65582	3-3
578434	2-3		
578437	2-9		
578439	3-3		
578441	2-5		
578445	2-5		
578446	2-5		
578569	2-9		
578571	2-9		
578577	2-3		
578579	2-3		
578591	2-9		
578592	2-9		
578597	2-3		
578706	2-9		
578707	2-9		
578710	2-5		
578711	2-5		
578712	2-5		
578713	2-5		
578725	2-5		
578727	2-5		
578733	2-5		
578743	2-5		
578747	2-3		
578779	2-11		
578800	2-5		
578801	2-3		
578802	2-5		
578805	2-5		
578806	2-5		
578807	4-2		
578808	4-2		
578809	4-2		
578810	4-2		
578811	4-2		
578812	4-2		
578813	4-2		

TENNANT SERVICE LITERATURE AVAILABLE...

A variety of information is available to you in forms to suit your needs. The following is a list of those publications that relate to the Model 443C family of machines:

Machine Model	Publication	Form	TENNANT Part No.
443C	Operator Manual and Parts Manual	Printed	MM294
443C	Operator Manual and Parts Manual	Microfiche	85294

Keep your manuals in a safe, convenient location for your future reference in order to operate, maintain, and order repair parts for your machine. Everyone who operates, maintains, or purchases parts for the machine should have easy access to a copy of the manual.

To get pricing information or to order copies of these publications, contact your nearest TENNANT parts warehouse, distributor, or sales representative.